

# DC-Micromotors

# 3 Watt

## Precious Metal Commutation

For combination with:  
 Gearheads:  
 14/1, 15/3, 15/5, 15/8  
 Encoders:  
 30B, 20/21B

### Series 1331 ... S

	1331 T	4,5 S	006 S	012 S	015 S	024 S		
1 Nominal voltage	$U_N$	4,5	6	12	15	24	Volt	
2 Terminal resistance	R	2,2	3,6	13,3	20,3	58,5	$\Omega$	
3 Output power	$P_{2 \max.}$	2,22	2,43	2,62	2,67	2,37	W	
4 Efficiency	$\eta_{\max.}$	77	78	77	76	75	%	
5 No-load speed	$n_o$	10 800	10 900	11 300	12 000	11 400	rpm	
6 No-load current (with shaft $\varnothing$ 1,5 mm)	$I_o$	0,035	0,025	0,015	0,014	0,008	A	
7 Stall torque	$M_H$	7,86	8,50	8,85	8,49	7,93	mNm	
8 Friction torque	$M_R$	0,14	0,13	0,15	0,16	0,16	mNm	
9 Speed constant	$k_n$	2 440	1 840	958	815	484	rpm/V	
10 Back-EMF constant	$k_E$	0,410	0,542	1,040	1,230	2,060	mV/rpm	
11 Torque constant	$k_M$	3,91	5,18	9,97	11,70	19,70	mNm/A	
12 Current constant	$k_I$	0,256	0,193	0,100	0,085	0,051	A/mNm	
13 Slope of n-M curve	$\Delta n/\Delta M$	1 370	1 280	1 280	1 410	1 440	rpm/mNm	
14 Rotor inductance	L	40	80	300	600	1 100	$\mu$ H	
15 Mechanical time constant	$\tau_m$	9	9	9	9	9	ms	
16 Rotor inertia	J	0,63	0,67	0,67	0,61	0,60	gcm <sup>2</sup>	
17 Angular acceleration	$\alpha_{\max.}$	130	130	130	140	130	$\cdot 10^3$ rad/s <sup>2</sup>	
18 Thermal resistance	$R_{th 1} / R_{th 2}$	8 / 40					K/W	
19 Thermal time constant	$\tau_{w1} / \tau_{w2}$	5 / 292					s	
20 Operating temperature range:								
– motor		– 30 ... + 85 (optional – 55 ... + 100)						°C
– rotor, max. permissible		+ 100						°C
21 Shaft bearings		sintered bronze sleeves	ball bearings	ball bearings, preloaded				
22 Shaft load max.:		(standard)	(optional)	(optional)				
– with shaft diameter		1,5	1,5	1,5			mm	
– radial at 3000 rpm (3 mm from bearing)		1,2	5	5			N	
– axial at 3000 rpm		0,2	0,5	0,5			N	
– axial at standstill		20	10	10			N	
23 Shaft play:								
– radial	$\leq$	0,03	0,015	0,015			mm	
– axial	$\leq$	0,2	0,2	0			mm	
24 Housing material		steel, zinc galvanized and passivated						
25 Weight		20					g	
26 Direction of rotation		clockwise, viewed from the front face						
<b>Recommended values</b>								
27 Speed up to	$n_{e \max.}$		12 000	12 000	12 000	12 000	12 000	rpm
28 Torque up to	$M_{e \max.}$		2,5	2,5	2,5	2,5	2,5	mNm
29 Current up to (thermal limits)	$I_{e \max.}$		0,750	0,580	0,300	0,240	0,140	A

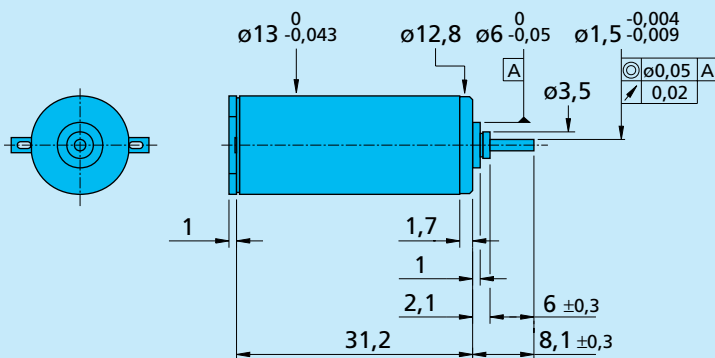

1331 T

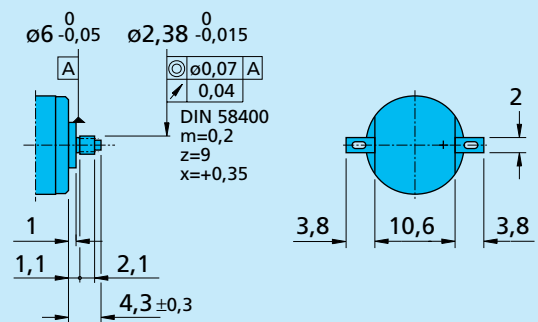

1331 E  
for Gearheads 15/...